

1 CLIENTE	CLIENT

E-MAIL

TEL - FAX

2 INFORMAZIONI GENERALI GENERAL INFORMATION

Nome dell'Imbarcazione
Boat Name

Cantiere
Shipyard

Tipo di costruzione
Construction type

Materiale
Material

3 IMPIEGO PURPOSE

4 DISLOCAMENTO (TON) DEPLASMAN (TON)

Mezzo carico Half weight

Pieno carico Full weight

5 DIMENSIONI GENERALI GENERAL DIMENSIONS

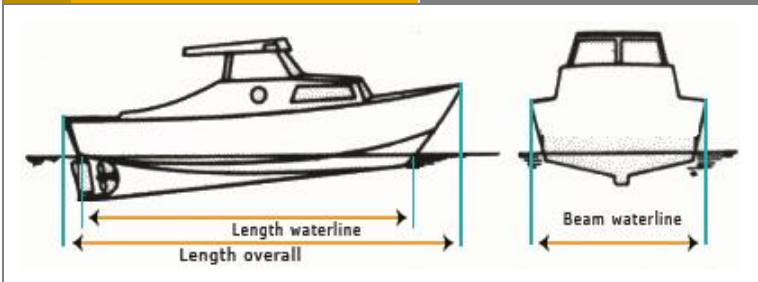

Lunghezza al galleggiamento Length waterline	METRI
Lunghezza totale Length overall	METRI
Larghezza al galleggiamento Beam waterline	METRI

6

M	mm
E	mm
S	mm
C	mm
R	mm
N	mm
K	mm
D	mm

7 MOTORE ENGINE

Marca Brand	Velocità di progetto Project speed
Tipo Type	Rapporto Riduzione Reduction
Numero motori Engine quantity	MAX giri motore Max engine revolutions
MAX Power HP – KW	

8 ROTAZIONE ELICA – VISTA POPPA-PRUA

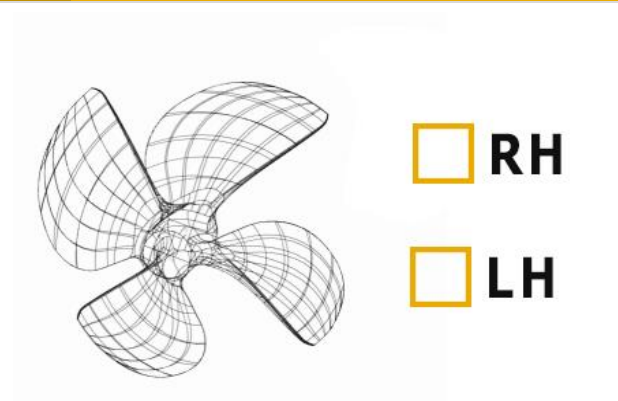

PROPELLER ROTATION – LOOKING AFT TO BOW

9 DIMENSIONI MOZZO – ELICA (mm)

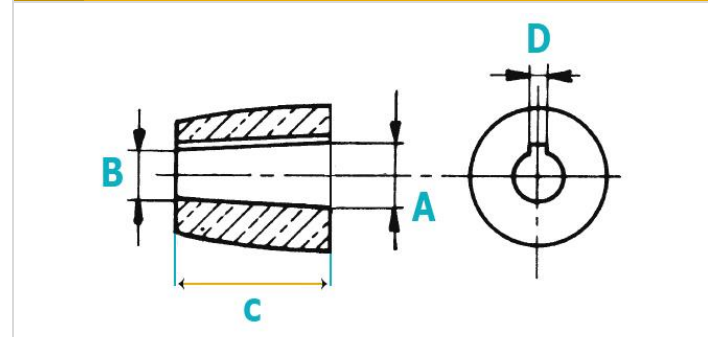

A:	B:	C:	D:
-----------	-----------	-----------	-----------

PROPELLER – HULL DIMENSION (mm)



OMNIMEC MARINE

(+39) 392-3660145
 (+39) 02-2829849
www.omnimec-marine.it
 info@omnimec-marine.it
V.LE MONZA 40 – 20127 – MILANO (MI) - ITALY - PI. VAT. 09129600962